

AMAL

1

AMAL

2

LIST No. 102/3 (Issue No. 2).
(Supersedes List No. 502)

HINTS AND TIPS

for

AMAL MONOBLOC CARBURETTER

Types 375, 376 and 389

Needle-jet Carburetters with pilot jets

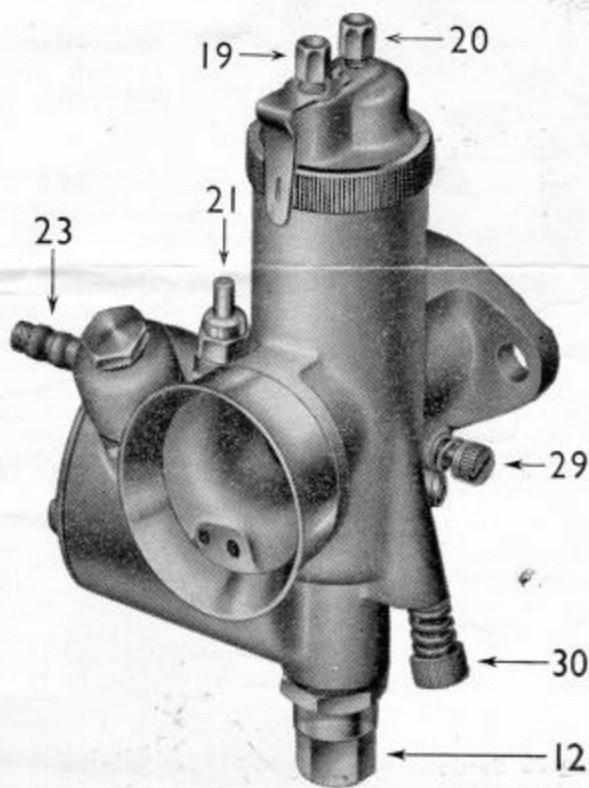

Fig. 1—Section through float chamber.

Sectional illustrations of Carburetters. Types 375, 376 and 389

(For key to diagram numbers see page 3).

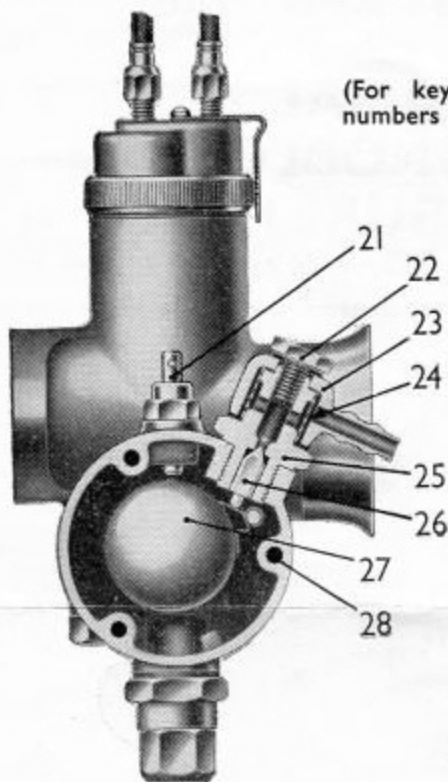

Fig. 2 — Section through mixing chamber, showing air valve and throttle closed.

(For key to diagram numbers see page 3)

INDEX.

- | | |
|---------------------------|------------------------------|
| 1—This page. | 5—How to trace faults. |
| 2—Section of carburetter. | 6—Parts to tune up with. |
| 3—How it works. | 7—How to tune up. |
| 4—Hints and tips. | 8—Service through Stockists. |
| 5—Re-assembling. | |

AMAL LTD., HOLDFORD ROAD, WITTON,
BIRMINGHAM 6, ENGLAND

Phone: Birmingham, BIRchfields 4571. Telegrams: "AMALCARB, PHONE,
(P.B.X. 6 lines) BIRMINGHAM."

The Carburetter of Records & Successes

3

HOW IT WORKS & PART NAMES

The carburetter proportions and atomises the right amount of petrol with the air that is drawn in by the engine because of the correct proportions of jet sizes and the main choke bore. The float chamber maintains a constant level of fuel at the jets and cuts off the supply when the engine stops.

The throttle control from the handlebar controls the volume of mixture and therefore the power, and at all positions of the throttle the mixture is automatically correct. The opening of the throttle brings first into action the mixture supply from the pilot jet system for idling, then as it progressively opens, via the pilot by-pass, the mixture is augmented from the main jet, the earlier stages of which action is controlled by the needle in the needle jet. The pilot jet system is supplied by a pilot jet which is detachable for cleaning purposes and which when assembled in the carburetter body is sealed by a cover nut. The main jet does not spray directly into the mixing chamber, but discharges through the needle jet into the primary air chamber, and goes from there as a rich petrol-air mixture through the primary air choke into the main air choke. This primary air choke has a compensating action in conjunction with bleed holes in the needle jet, which serve the double purpose of air compensating the mixture from the needle jet and allowing the fuel to provide a well outside and around the needle jet, which is available for snap acceleration.

The carburetters usually have a separately operated mixture control called an air valve, for use when starting from cold, and until the engine is warm; this control partially blocks the passage of air through the main choke.

This design of carburetter offers perfectly simple and effective tuning facilities.

- | | |
|-------------------------------|-------------------------------|
| 1—Mixing Chamber Top. | 19—Cable Adjuster (Air). |
| 2—Mixing Chamber Cap. | 20—Cable Adjuster (Throttle) |
| 3—Carburetter Body. | 21—Tickler. |
| 4—Jet Needle Clip. | 22—Banjo Bolt. |
| 5—Throttle Valve. | 23—Banjo. |
| 6—Jet Needle. | 24—Filter Gauze. |
| 7—Pilot outlet. | 25—Needle Seating. |
| 8—Pilot by-pass. | 26—Needle. |
| 9—Pilot Jet. | 27—Float. |
| 10—Petrol feed to pilot jet. | 28—Side Cover Screws. |
| 11—Pilot Jet Cover Nut. | 29—Pilot Air Adjusting Screw. |
| 12—Main Jet Cover. | 30—Throttle Adjusting Screw. |
| 13—Main Jet. | 31—Air to pilot jet. |
| 14—Jet Holder. | 32—Feed holes in pilot jet. |
| 15—Needle Jet. | 33—Bleed holes in needle jet. |
| 16—Jet Block. | 34—Primary Air Choke. |
| 17—Air Valve. | 35—Primary Air Passage. |
| 18—Mixing Chamber Cap Spring. | 36—Throttle Valve Cutaway. |

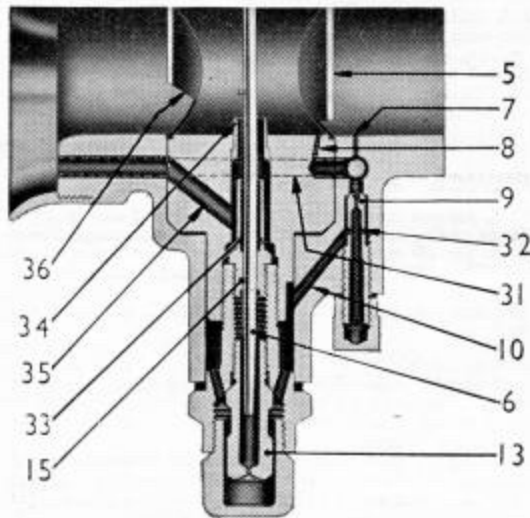

Fig. 3.

Diagrammatic section of Carburetter showing only the lower half of the throttle chamber with the throttle a little open—and the internal primary air passages to the main jet and pilot system.

FOR KEY TO DIAGRAM NUMBERS SEE ABOVE.

4

HINTS AND TIPS

STARTING from Cold. Flood the carburetter by depressing the tickler sharply three or four times, and close the air valve; set the ignition, say half retard. Then shut the throttle and open it a little, viz., about one-eighth open, see figure 5, page 7 position 2, then kick-start. If it is too much open starting will be difficult.

STARTING, engine hot. Do not flood the carburetter but close the air valve. Set the ignition and close the throttle, then open the throttle about one-eighth of its travel and kick-start. If the carburetter has been flooded and won't start because the mixture is too rich—open the throttle wide and give the engine several turns to clear the richness, then start again with the throttle one-eighth open, and air valve wide open. Generally speaking it is not advisable to flood at all when an engine is hot.

STARTING, general. By experiment, find out if and when it is necessary to flood, also note the best position for the air valve and the throttle for the easiest starting.

STARTING, SINGLE LEVER CARBURETTERS. OPEN THE THROTTLE VERY SLIGHTLY FROM THE IDLING POSITION AND FLOOD THE CARBURETTER MORE OR LESS ACCORDING TO THE ENGINE BEING COLD OR HOT RESPECTIVELY.

CABLE CONTROLS. See that there is a minimum of backlash when the controls are set back and that any movement of the handlebar does not cause the throttle to open; this is done by the adjusters on the top of the carburetter. See that the throttle shuts down freely.

PETROL FEED, verification. Later models are fitted with a filter gauze at the inlet to the float chamber. To remove the filter gauze unscrew the banjo bolt (22), the banjo can then be removed and the filter gauze withdrawn from the needle seating. Ensure that the filter gauze is undamaged and free from all foreign matter. Before replacing banjo turn on petrol tap momentarily and see that fuel gushes out. Avoid petrol pipes with vertical loops as they cause air locks. Flooding may be due to a worn needle or a damaged float, but nearly all flooding with new machines is due to impurities (grit, fluff, etc.) in the tank—so clean out the float chamber periodically till the trouble ceases. If the trouble persists, the tank might be drained, swilled out, etc.

FIXING CARBURETTER AND AIR LEAKS. Erratic slow running is often caused by air leaks, so verify there are none at the point of attachment to the cylinder or inlet pipe—check by means of an oil can and eliminate by new washers and the equal tightening up of the flange nuts. On later models a sealing ring is fitted into the attachment flange of the carburetter. Also in old machines look out for air leaks caused by a worn throttle or worn inlet valve guides.

BANGING IN EXHAUST may be caused by too weak a pilot mixture when the throttle is closed or nearly closed—also it may be caused by too rich a pilot mixture and an air leak in the exhaust system; The reason in either case is that the mixture has not fired in the cylinder and has fired in the hot silencer. If the banging happens when the throttle is fairly wide open the trouble will be ignition—not carburation.

BAD PETROL CONSUMPTION of a new machine may be due to flooding, caused by impurities from the petrol tank lodging on the float needle seat and so prevent its valve from closing. Flooding may be caused by a worn float needle valve. Also bad petrol consumption will be apparent if the needle jet (15) (see fig. 2) has worn; it may be remedied or improved by lowering the needle in the throttle, but if it cannot be—then the only remedy is to get a new needle jet.

AIR FILTERS. These may affect the jet setting, so if one is fitted afterwards to the carburetter the main jet may have to be smaller. If a carburetter is set with an air filter and the engine is run without it, take care not to overheat the engine due to too weak a mixture; testing with the air valve (page 5), will indicate if a larger main jet and higher needle position are required.

EFFECT OF ALTITUDE ON CARBURETTER. Increased altitude tends to produce a rich mixture. The greater the altitude, the smaller the main jet required. Carburetters ex-works are set suitable for altitudes up to 3,000 feet approximately. Carburetters used constantly at altitudes 3,000 to 6,000 feet should have a reduction in main jet size of 5 per cent., and thereafter for every 3,000 feet in excess of 6,000 feet altitude further reductions of 4 per cent. should be made.

RE-ASSEMBLING

RE-ASSEMBLING after dismantling. See that the washer on the bottom of the jet block is in good condition, otherwise fuel will leak across its face causing rich erratic running, if the washer is faulty it should be replaced by a new one. When replacing the throttle see that the jet needle goes into the centre hole in the jet block and once in, note the throttle works freely when the mixing chamber cap (2) is screwed down firmly and held by spring (18).

When re-assembling the float see that the narrow leg portion of its hinge is uppermost, as this operates the needle. Care should be taken to see that the joint faces of the side cover and body are not damaged or bruised and that the joint washer is in good condition, otherwise difficulty will be experienced in making a petrol tight joint.

On certain rod controlled air valve operated carburettors both the air valve and rod are screwed to enable adjustment for various bores. It is important to ensure that when reassembling in the carburettor the air valve fully closes when the click spring is engaged in the groove of the air valve rod.

HOW TO TRACE FAULTS

There are only two possible faults in carburation, either richness or weakness of mixture.

INDICATIONS OF:—

RICHNESS.

- Black smoke in exhaust.
- Petrol spraying out of carburettor.
- Four strokes, eight-stroking.
- Two strokes, four-stroking.
- Heavy, lumpy running.
- Sparkling plug sooty.

WEAKNESS.

- Spitting back in carburettor.
- Erratic slow running.
- Overheating.
- Acceleration poor.
- Engine goes better if:—
 - Throttle is not wide open or
 - Air Valve is partially closed.

If richness or weakness is present, check if caused by:—

- | | |
|--|---|
| <p>(1) Petrol feed.</p> <p>(2) Air leaks.</p> <p>(3) Defective or worn parts.</p> <p>(4) Air cleaner being choked up.</p> <p>(5) An air cleaner having been removed.</p> | <p>Check that jets and passages are clear, that filter gauze in float chamber banjo connection is not choked with foreign matter, and that there is ample flow of fuel.</p> <p>Check there is no flooding.</p> <p>At the connection to the engine or due to leaky inlet valve stems.</p> <p>As a loose fitting throttle valve, worn needle jet, loose jets.</p> |
|--|---|

Removing the silencer or running with a straight through pipe requires a richer setting.

Having verified the correctness of fuel feed and that there are no air leaks, check over ignition, valve operation and timing. Now at throttle position shown on page 7, fig. 5, test to see if mixtures are rich or weak. This is done by partially closing the air valve, and if engine runs better weakness is indicated, but if engine runs worse richness is indicated.

To remedy, proceed as follows:—

To cure richness.

- Position 1. Fit smaller main jet.
- Position 2. Screw out pilot air adjusting screw.
- Position 3. Fit a throttle with larger cutaway (para. F, page 6).
- Position 4. Lower needle one or two grooves (para. E, page 6).

To cure weakness.

- Fit larger main jet.
- Screw pilot air adjusting screw in.
- Fit a throttle with smaller cutaway (para. F, page 6).
- Raise needle one or two grooves (para. E, page 6).

NOTE. It is not correct to cure a rich mixture at half throttle by fitting a smaller main jet because the main jet may be correct for power at full throttle: the proper thing to do is to lower the needle.

PARTS TO TUNE UP WITH

(a) This fig. 4 is three diagrammatic sections of the carburettor to show the throttle adjusting screw (30), and the pilot air adjusting screw.

(b) **THROTTLE ADJUSTING SCREW.**

Set this screw to hold the throttle open sufficiently to keep the engine running when the twist grip is shut off.

(c) **PILOT AIR ADJUSTING SCREW.**

This screw regulates the strength of the mixture for "idling" and for the initial opening of the throttle. The screw controls the depression on the pilot jet by metering the amount of air that mixes with the petrol.

FOR KEY TO DIAGRAM NUMBERS SEE PAGE 3.

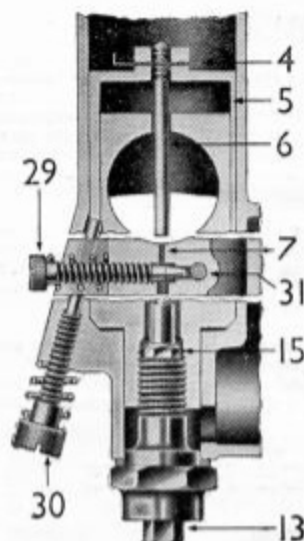

Fig. 4.



(d) **MAIN JET.** The main jet controls the petrol supply when the throttle is more than three-quarters open, but at smaller throttle openings although the supply of fuel goes through the main jet, the amount is diminished by the metering effect of the needle in the needle jet.

Each jet is calibrated and numbered so that its exact discharge is known and two jets of the same number are alike. **NEVER REAMER A JET OUT, GET ANOTHER OF THE RIGHT SIZE.** The bigger the number the bigger the jet.

To remove the main jet unscrew the main jet cover, the exposed main jet can then be unscrewed from the jet holder.

(e) **NEEDLE AND NEEDLE JET.** The needle is attached to the throttle valve and being taper—either allows more or less petrol to pass through the needle jet as the throttle is opened or closed throughout the range, except when idling or nearly full throttle.

The taper needle position in relation to the throttle opening can be set according to the mixture required by fixing it to the throttle valve with the jet needle clip in a certain groove (see figure 4 above), thus either raising or lowering it. Raising the needle enriches the mixture and lowering it weakens the mixture at throttle openings from quarter to three-quarters open (see figure 5, page 7). The needles are marked with the letters B, C, or D. B type are fitted in the 375 Carburettor, C type in the 376 Carburettor, and D type in the 389 Carburettor. The needles in some cases are marked with a number in addition to a letter.

(f) **THROTTLE VALVE CUT-AWAY.** The atmospheric side of the throttle is cut away to influence the depression on the main fuel supply and thus gives a means of tuning between the pilot and needle jet range of throttle opening. The amount of cut-away is recorded by a number marked on the throttle valve, viz., 376/3 means throttle valve type 376 with No. 3 cut-away; larger cut-aways, say 4 and 5, give weaker mixtures and 2 a richer mixture.

(g) **AIR VALVE** is used only for starting and running when cold, and for experimenting with, otherwise run with it wide open.

(h) **TICKLER,** a small plunger spring loaded, in the float chamber wall. When pressed down on the float, the needle valve is allowed to open and so "flooding" is achieved. Flooding temporarily enriches the mixture until the level of the petrol subsides to normal.

ALCOHOL FUELS. When using alcohol fuels the following new components are necessary. Needle Jet 376/117, Jet Needle 376/116 or 389/088 according to type of carburettor, Needle Seating 376/118, Float Needle 376/161 and possibly a double feed Banjo if not already fitted. The Main Jet must be increased for straight alcohol by approximately 150%. The final setting must be a question of trial and error according to the nature of fuel used.

When using alcohol fuels it is advisable to err on the rich side to avoid engine overheating.

HOW TO TUNE UP

PHASES OF AMAL NEEDLE JET CARBURETTER THROTTLE OPENINGS

Up to $\frac{1}{2}$ open from $\frac{1}{4}$ to $\frac{1}{2}$ open $\frac{1}{2}$ to $\frac{3}{4}$ open $\frac{3}{4}$ to full open
PILOT JET **THROTTLE** **NEEDLE-** **MAIN JET**
CUT-AWAY **CUT-AWAY** **POSITION** **SIZE**

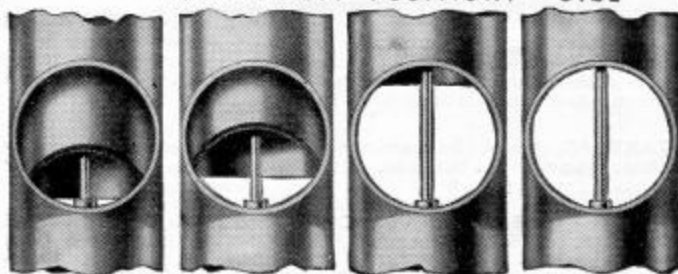

2ND & 5TH 3RD 4TH 1ST
SEQUENCE OF TUNING

FIG. 5.

TUNE UP IN THE FOLLOWING ORDER.

NOTE. The carburetter is automatic throughout the throttle range—the air valve should always be wide open except when used for starting or until the engine has warmed up. We assume normal petrols are used.

READ REMARKS ON PAGES 6 AND 7 for each tuning device and get the motor going perfectly on a quiet road with a slight up gradient so that on test the engine is pulling.

1st MAIN JET with throttle in position 1 (fig. 5).

If at full throttle the engine runs "heavily" the main jet is too large. If at full throttle by slightly closing the throttle or air valve the engine seems to have better power, the main jet is too small.

With a correct sized main jet the engine at full throttle should run evenly and regularly with maximum power.

If testing for speed work ensure that the main jet size is sufficient for the mixture to be rich enough to keep the engine cool, and to verify this examine the sparking plug after taking a fast run, declutching and stopping the engine quickly. If the plug body at its end has a cool appearance the mixture is correct: if sooty, the mixture is rich: if however there are signs of intense heat, the mixture is too weak and a larger main jet is necessary.

2nd. PILOT JET (fig. 5) with throttle in positions 2 and 5.

With engine idling too fast with the twist grip shut off and the throttle shut down on to the throttle adjusting screw, and ignition set for best slow running: (1) Screw out throttle adjusting screw until the engine runs slower and begins to falter, then screw pilot air adjusting screw in or out, to make engine run regularly and faster. (2) Now gently lower the throttle adjusting screw until the engine runs slower and just begins to falter, adjust the pilot air adjusting screw to get best slow running: if this 2nd adjustment make engine run too fast, go over the job again a third time.

3rd. THROTTLE CUT-AWAY with throttle in position 3 (fig. 5)

If, as you take off from the idling position, there is objectionable spitting from the carburetter, slightly richen the pilot mixture by screwing in the air screw sufficiently, but if this is not effective, screw it back again, and fit a throttle with a smaller cut-away. If the engine jerks under load at this throttle position and there is no spitting, either the jet needle is much too high or a larger throttle cut-away is required to cure richness.

4th. NEEDLE with throttle in position 4 (fig. 5).

The needle controls a wide range of throttle opening and also the acceleration. Try the needle in as low a position as possible, viz., with the clip in a groove as near the top as possible; if acceleration is poor and with air valve partially closed the results are better, raise the needle by two grooves; if very much better try lowering needle by one groove and leave it where it is best. If mixture is still too rich with clip in groove No. 1 nearest the top—the needle jet probably wants replacement because of wear. If the needle itself has had several years' use replace it also.

5th FINALLY go over the idling again for final touches.

TUNING TWIN ENGINES WITH TWIN CARBURETTERS

where each cylinder has its own Carburetter.

First of all, slacken the Throttle stop screws and put the Twist Grip into the shut off position to allow the Throttles to shut off; there should be a slight back lash in the cables which back lash can be obtained, if necessary, by screwing in the cable adjusting screws on the top of the Carburetter. Then, with the Handlebars in the normal position, and with the Throttles closed, adjust the cable adjusting screws so that on the slightest opening of the Twist Grip, both Throttles begin to open simultaneously.

To set the Carburetters, follow the procedure as given on page 7, and bear in mind these "Hints," which may be useful—Main Jet sizes are of course selected by checking the effect of the Mixture on the Sparking Plugs after taking a run at full throttle over a straight piece of road; the smallest pair of jets that give the best maximum speed are usually correct provided that the Plugs do not show any signs of excessive heat. It might be that for really critical tuning, one Carburetter might require a slightly different Jet size from the other.

For slow running, set the Twist Grip to make the Engine run slowly but just faster than a "tick over"; then gently screw in the Throttle stops to just hold the Throttles in that position, and return the Twist Grip into the shut position, leaving the Engine running on the Throttle Stops.

The next thing to do is to set each Carburetter according to paragraph 2, on Page 7, to obtain the idling by screwing down the Throttle Stop Screws and adjusting the Pilot Air Screws accordingly.

Regarding the setting of the Pilot, a fairly satisfactory method is to detach one Sparking Plug lead, and set the Pilot Air Adjusting Screw on the other Cylinder as a single unit, and then reversing the process to the other Cylinder. It may be found that when both leads are connected to the Sparking Plugs, the Engine runs slightly quicker than desirable, in which case, a slight readjustment of the Throttle Stop Screws will put this right. It is essential that the speed of idling on both Cylinders is approximately the same, as this will either make or mar the smoothness of the get-away on the initial opening of the Throttle.

It is essential with Twin Carburetters that the Throttle Slides are a good fit in the bodies, and also that there is no suspicion of air leaks at either of the flange attachments to the Cylinder.

Regarding the lower end of the Throttle range, which is always the more difficult to set, one can only take excessive pains to make quite sure that the Control Cables are perfectly adjusted, without any excessive back lash or difference in the amount of back lash between one Carburetter and another; otherwise one Throttle slide will be out of phase with the other, and so resulting in lumpy running.

To check the opening of the Throttle simultaneously, shut the Twist Grip back so that the Throttles are resting on the Throttle Stop Screws in their final position of adjustment; then insert the fingers into the air intakes and press them on the Throttles and with the other hand, gently open by the Twist Grip and feel that the Throttles lift off their stops at the same time.

WHEN USING A REMOTE FLOAT CHAMBER. The fuel level should be set in line with the raised point below the name Amal on the side cover of the mixing chamber. This level is indicated externally on types 510 and 504 Float Chambers by a line. The type 302 level is $1\frac{1}{8}$ " below the cover joint face. This setting must take place when the machine is not on its stand and on level ground.

SERVICE ARRANGEMENTS

There are many AMAL Service Stockists in Great Britain and also in other countries where Motor-cycling is popular: They have information about recommended settings for all standard machines and, you are strongly advised to purchase GENUINE AMAL SPARES through them, at our List prices.

ALL GENUINE JETS are stamped with the name AMAL and with the Calibration Number.

GUARANTEE.

The Company take all possible reasonable care in the manufacture and the quality of their products. Purchasers are informed that, any part proved to be defective in manufacture or quality, and returned to the works within six months of its purchase new, will be replaced.

The Company must respectfully point out however, that its responsibility and that of its agents, stockists and dealers, is limited to this Guarantee, and that they cannot, under any circumstances, be held responsible for any loss or for any contingent or resulting liability arising through any defect.

The conditions of sale and use also apply when the Company's products form part of the original equipment of machines purchased new.

50,000/5/65. W.

Printed in England